

<http://www.sofistik.gr/>

Steel Structures

New version of program STEELCON 2015.286

**SteelCon**

**New connections between tubes. KNEE type connections.**

Dear colleagues,

A new version of the “**STEEL CONnections**” program for the design of bolted and welded steel connections has been released. This version offers many new features:

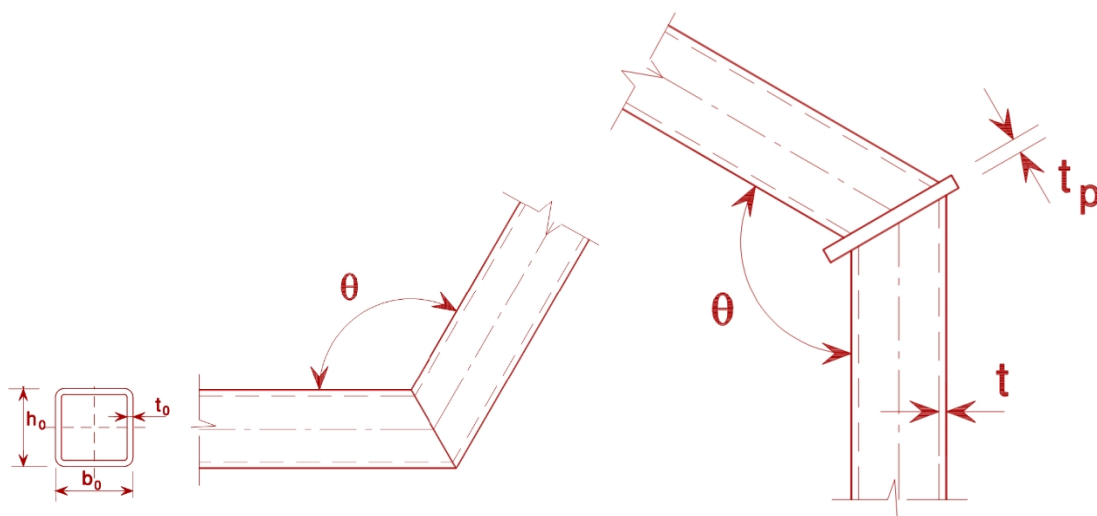

The types of the connections according to the connected member types are:

RHS Chord  
SHS Chord

The checks that are performed are based at chap. 7 of EN 1993-1-8 and are:

Chord face failure for Axial force.  
Chord face failure for in-plane Moment.

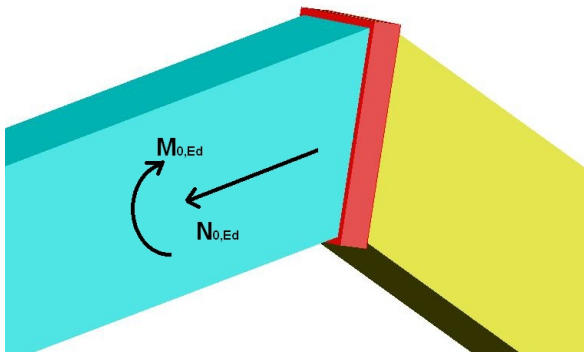

Based on the geometrical characteristics of the nodes, the rule defines a range of connections that can be analytically calculated. The validity range evaluation ensures that the failure modes of the connection will be the same with the expected ones by the rule.

For connections that belong into the validity range, some failure types can be neglected under certain conditions, but for connections outside that range some failure modes that are not documented in the rule and need separate handling may happen.

The program performs all the necessary geometrical checks and informs the user in the case that the node is out of the range of validity.

The members may be subjected to axial force and in-plane moment. The program calculates the interaction of these forces according to EN 1993-1-8.

SteelCON is SOFiSTiK Version 27 (2012) as well as Version 30 (2014) compatible and can be operated within the SSD integrated SOFiSTiK environment. All geometrical and topological data as well as forces can be imported from the overall structure. Connection design results are then a part of the SOFiSTiK Output Report.

Installs the following Plugins :  
- SSD V30 Plugin (and SSD V27 plugin)

1.11.2015, Munich Germany

Ομάδα υποστήριξης SOFiSTiK Hellas A.E.